

Your Global Automation Partner

TURCK

EZ-track[®] R10 Series Analog Output

Manual

EZ-track™ Contents

Chapter 1: Overview	3
1.1 Dimension Drawing for LT R10 LDTs	3
Chapter 2: Installing the LDT	4
2.1 Installing the LDT to a Mounting Bracket	4
2.2 Installing the LDT in a Hydraulic Cylinder	6
Chapter 3: LT R10 Wiring	9
3.1 LT R10 Analog - LU (Voltage)	10
3.2 LT R10 Analog - LI (Current)	10
3.3 LT R10 Analog - LD (Differential)	10
3.4 LT R10 Analog Wiring	10
3.5 Setting Zero & Span Position	10
3.6 Setting Zero & Span Position - LD (Differential Analog) Only	11
Appendix A: Troubleshooting	12
A.1 Troubleshooting for LT R10 Analog LDTs	12
Appendix B: Ordering Information	13
B.1 Analog Part Numbering	13
B.2 Accessories	13
Appendix C: Specifications	14

Chapter 1: Overview

Note:

Turck has checked the accuracy of this manual at the time it was approved for printing. However, this manual may not provide all possible ways of installing and maintaining the LDT. Any errors found in this manual or additional possibilities to the installation and maintenance of the LDT will be added in subsequent editions. Any comments you may have for the improvement of this manual are welcomed.

Turck reserves the right to revise and redistribute the entire contents or selected pages of this manual. All rights to the contents of this manual are reserved by Turck. EZ-track is a registered trademark of Turck.

The Turck Model LT R10 EZ-track is a Magnetostrictive Linear Displacement Transducer (LDT). Each LDT offers highly accurate position sensing. The EZ-track LDT is built to withstand the most severe environmental conditions. The LT R10 digital and analog LDTs are completely absolute. Power loss will not cause the unit to lose position information or require re-zeroing. Also, the non contact design allows this device to be used in highly repetitive applications without mechanical wear.

Note:

The series number on the LDT is a record of all the specific characteristics that make up the unit. This includes what interface type it is its output signal and range; the type of connector the unit uses; and stroke, null and dead band lengths. For a translation of the model number, see Appendix B: Ordering Information.

The Turck LT R10 EZ-track is a magnetostrictive Linear Displacement Transducer (LDT) for continuous machine positioning in a variety of industrial applications.

1.1: Dimension Drawing for LT R10 LDTs

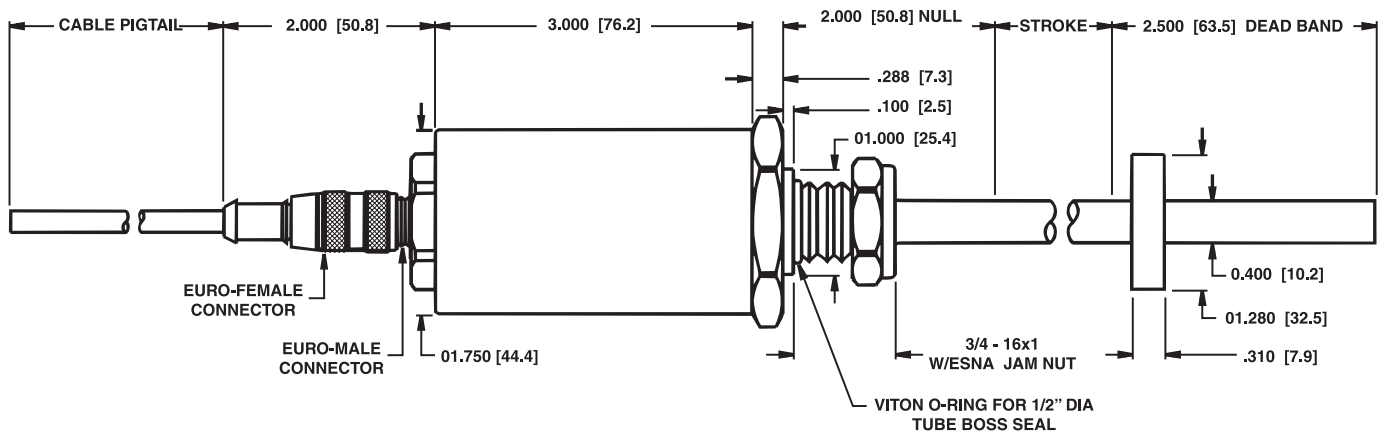

Figure 1-1: Mounting LDT in a Hydraulic Cylinder

Chapter 2: Installing the LDT

Before installing the LDT, the following should be considered:

- If a mounting bracket is used that is made of ferromagnetic material (a material readily magnetized), it should be placed no closer than 0.25" from the LDT's rod end.
- To minimize the effects of magnetic flux distortion (which could cause an inaccurate measurement of the magnet's position), ferromagnetic material should not be placed closer than 0.25" from the magnet.

2.1: Installing the LDT to a Mounting Bracket

Perform the following steps to install the LDT to a mounting bracket. Parts discussed in this section are found in Figure 1-1. If the LDT is being installed into a hydraulic cylinder, refer to Section 2.2: Installing the LDT in a Hydraulic Cylinder.

1. Unscrew the LDT's jam nut from the threads protruding from the hex mounting base.
2. Insert the LDT's rod end into the mounting bracket's hole. The mounting bracket may contain a 3/4 – 16 UNF – 2B threaded hole. In this case, screw the LDT into this hole using the threads protruding from the hex mounting base.
3. Once the LDT is in place, screw the jam nut back onto the threads of the hex mounting base. Use the 1.75" hex mounting base on the head assembly to tighten the LDT to the bracket.

WARNING:

Do not use the black aluminum cover of the head assembly or connector to tighten the LDT within the bracket (see Figure 2-1). This may damage the LDT and will void your warranty. To tighten the LDT within the bracket, use the 1.75" hex mounting base on the head assembly.

If the length of the LDT's rod end is less than 30", skip to the sub-section: Mounting the Magnet Assembly.

Installing Support Brackets

It is recommended that a support bracket be used with LDTs having a rod 30"-71" in length. Supporting the end of the rod will minimize operational errors and protect against damage due to shock and vibration. If the length of the LDT's rod is 72" or longer, it is recommended that additional support brackets be used. These additional support brackets must be made of a non-ferrous material. Because these additional support brackets will interfere with the magnet's movement, a special split-type magnet assembly must be used.

To order a split magnet (**SPM-AL-R10**) and support brackets (**RB-R10**), contact Factory. To install a support bracket for a LDT having a rod 30"-71" in length, perform step 4a. If the rod is longer than 71", perform step 4b.

- 4a. If the support bracket is made of a ferromagnetic material (material readily magnetized), install the support bracket no closer than 0.25" from where the LDT's dead band ends and the area of stroke begins. Continue to the sub-section: Mounting the Magnet Assembly.

To install two or more support brackets for a LDT having a rod 72" or longer in length, perform the following steps:

- 4b. Install support brackets at increments of 48" throughout the LDT's rod. Support brackets placed within the null zone and area of stroke or closer than 0.25" to the beginning of these areas must be made of a non-ferrous material.

Mounting the Magnet Assembly

Before mounting the magnet assembly, the following should be considered:

- Ferromagnetic material should not be placed closer than 0.25" from the LDT's magnet assembly or rod end. Failure to do so could cause erratic operations. Non-ferrous materials, such as brass, copper, aluminum, non-magnetic stainless steel or plastics, can be in direct contact with the magnet assembly and rod end without producing any adverse results.
- Minimal clearance between the LDT's rod and the magnet assembly through the full stroke is required. Stress between the magnet and the rod can cause flexing of the mounting brackets. This may appear as nonlinearity.
- LDTs using a split magnet assembly must keep the diameter of the magnet assembly around the rod throughout the complete stroke. The diameter of this magnet assembly should not be farther than 0.2" away from the rod. Split magnet assemblies outside this range will cause signal loss.

To install the magnet assembly, perform the following steps:

1. Slide the magnet assembly over the LDT rod.
2. Mount the magnet to the non-ferrous, movable portion of the device being controlled using nonferrous screws.

2.2: Installing the LDT in a Hydraulic Cylinder

Before installing an LDT in a hydraulic cylinder, note the following considerations. Items discussed in this section are found in Figures 1-1 and 2-1.

- A non-ferrous spacer must be used to separate the magnet assembly from the head of the piston rod. See Figure 2-1.
- The magnet should not be closer than 2.0" from the base of the LDT's hex head when the piston rod is fully retracted. In instances where space restraints exist, it may be required to countersink the magnet into the piston rod. Two magnets are available for mounting to the piston: the standard 1.29" in diameter (**STM-AL-R10**) four-hole magnet and a 1.0" magnet (**CM-R10**) designed exclusively for countersunk mounting applications. The 1.0" magnet must be held captive with a snap ring.
- An O-ring groove is provided at the base of the LDT's mounting hex for pressure sealing. The O-Ring seal was designed to meet Mil-Std- MS33656. Refer to SAE J514 or SAE J1926/1 for machining of mating surfaces.
- It is recommended that a chamfered rod bushing be used with LDTs having a rod 60.0" or longer in length. On applications with rods of this length, a chamfered rod bushing in front of the magnet may be required. This bushing will prevent wear on the magnet assembly (wear occurs as the piston retracts from extended lengths). This rod bushing should be manufactured from a high wear polymer, such as PTFE.
- It is recommended the bore for the cylinder piston rod have an inside diameter of at least 0.50". The LDT rod has an outside diameter of 0.405". Use standard practices for machining and mounting these components. Consult the cylinder manufacturer for details on applicable SAE or military specifications.

Before performing the following steps for installing the LDT into a hydraulic cylinder, it may be necessary to perform machining and mounting operations on the hydraulic cylinder. Consult the information and specifications provided by the cylinder manufacturer before beginning the following steps:

1. Unscrew the LDT's jam nut from the threads protruding from the hex mounting base.
2. Position the non-ferrous spacer against the piston face, followed by the magnet, and finally the chamfered rod bushing. (If the length of the LDT's rod is 60.0" or longer in length, it is recommended that a chamfered rod bushing be used.)
3. Insert non-ferrous screws through the chamfered rod bushing (if used), magnet, and non-ferrous spacer, and secure items by tightening screws. If the leading edge of the magnet will come closer than 2.0" from the base of the LDT's hex head when the piston rod is fully retracted, it will be necessary to counter-bore the magnet assembly into the piston rod. Both the standard 1.29" four-hole magnet assembly (**STM-AL-R10**) and the 1.0" magnet assembly (**CM-R10**) are designed for counter-bored mounting applications. If it has a 1.0" magnet assembly, a snap ring will be needed to hold it in place.
4. Insert the LDT's rod into the hole of the hydraulic cylinder's mounting bracket. The protective Plug may need to be removed from the hydraulic cylinder before inserting the LDT. The end cap should contain a 3/4 - 16 UNF - 2B threaded hole. Screw the LDT into this hole using the threads protruding from the LDT's hex mounting base.

WARNING:

Do not use the black aluminum cover of the head assembly or connector to tighten the LDT within the bracket (see Figure 2-1). This may damage the LDT and will void your warranty. To tighten the LDT within the bracket, use the 1.75" hex mounting base on the head assembly.

At this point, the LDT should now be properly installed inside the hydraulic cylinder. It may now be necessary to assemble parts of the hydraulic cylinder. For assistance in this task, refer to the information provided by the cylinder manufacturer.

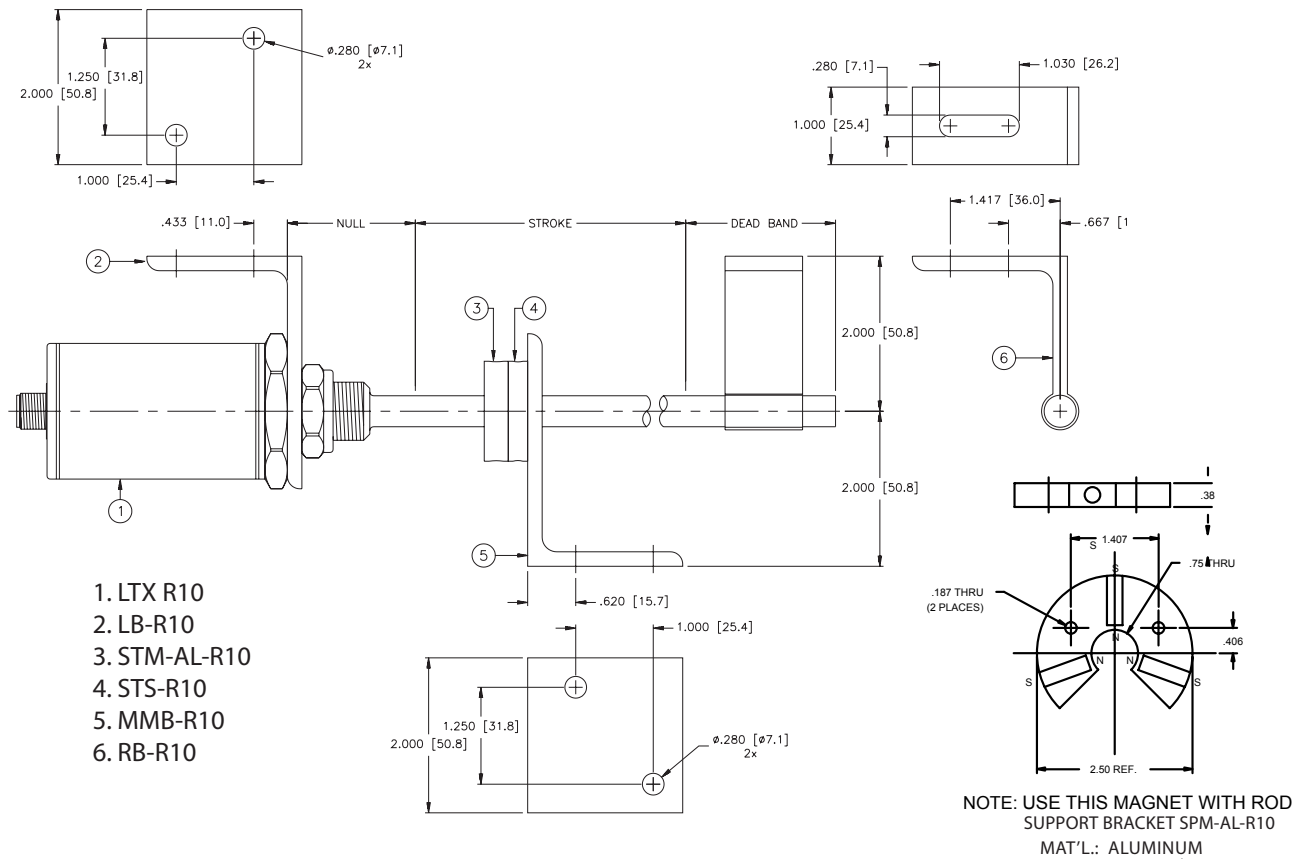

Figure 2-1: Mounting the LDT

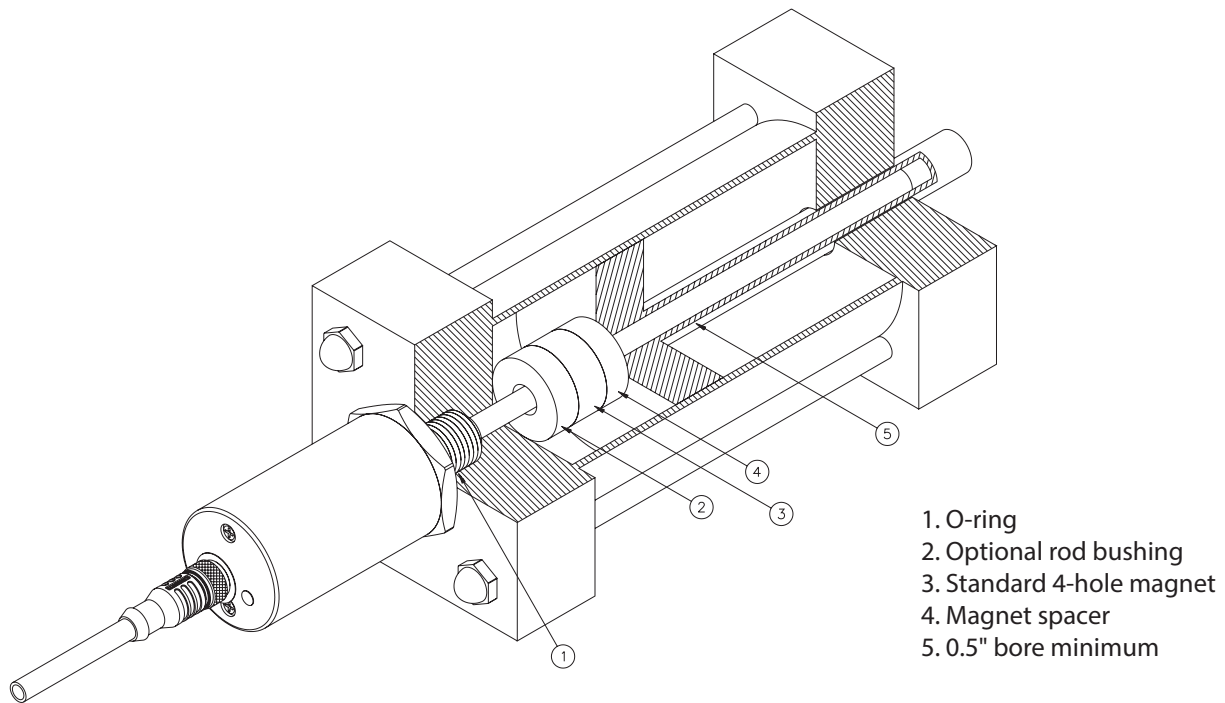
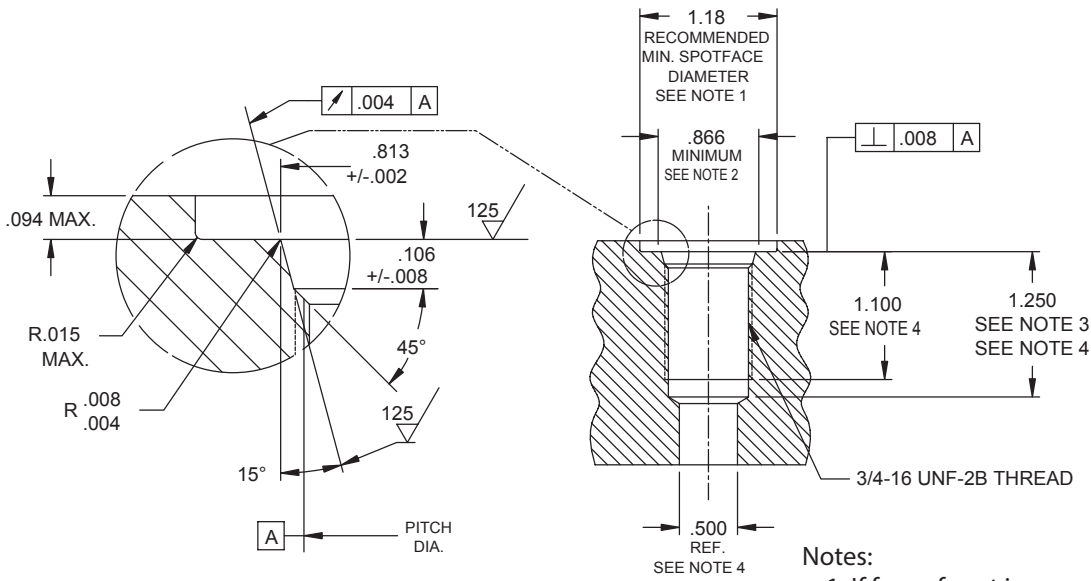

Figure 2-2: Mounting LDT in a Hydraulic Cylinder



Notes:

1. If face of port is on a machined surface, dimensions 1.180 and .094 need not apply as long as R.008/.0004 is maintained to avoid damage to the o-ring during assembly.
2. Measure perpendicularity to A at this diameter.
3. This dimension applies when tap drill cannot pass through entire boss.
4. This dimension does not conform to SAE J1926-1.

Figure 2-3: Port Detail (SAE J1926/1)

Chapter 3: LT R10 Wiring Connections

Once the LDT has been installed, wiring connections can be made. There are two groups of connections that will need to be made. They are as follows:

- Power Supply Connections
(including grounding and shielding)
- LDT Input/Output Connections

Power Supply/Ground Connections

The EZ-track standard cable is the RK 4.5T-*/S618, a multi-conductor cable with a pvc jacket, 5 conductors of 22 AWG, with an aluminum/polyester foil SHIELD and drain wire. Cable O.D. is 5.69mm. To reduce electrical noise the shield must be properly used. Connect the cable's shield to the controller system GND. The cable shield is not connected at the transducer rod. Always observe proper grounding techniques such as single point grounding and isolating high voltage (i.e. 120/240 VAC) from low voltage (13.5 - 30 VDC cables for analog LDTs).

Warning:
Do not use molded cordsets with LED's

It is preferable that the cable between the LDT and the interface device be one continuous run. If you are using a junction box, it is highly recommended that the splice junction box be free of AC and/or DC transient-producing lines. The shield should be carried through the splice and terminated at the interface device end.

Note:

When grounding the LDT, a single earth ground should be connected to the power supply common (circuit ground). The LDT power supply common (pin 3) should be connected to the power supply common (-) terminal. Pin 1 should be connected to the power supply positive terminal (+). The LDT cable shield should be tied to earth ground at the power supply. The LDT analog common should not be connected to earth ground and should be used for connection to interface devices only. For assistance, refer to your LDT's wiring drawing in this chapter.

Warning:

Do not use the black aluminum cover of the head assembly or connector/cable nut to tighten the LDT within the bracket (see Figure 2-1). This may damage the LDT and will void your warranty. To tighten the LDT within the bracket, use the 1.75" hex mounting base on the head assembly.

At this point, the LDT should now be properly installed inside the hydraulic cylinder. It may now be necessary to assemble parts of the hydraulic cylinder. For assistance in this task, refer to the information provided by the cylinder manufacturer.

Wiring

In order for the EZ-track to operate properly, the LDT's external power supply must provide a voltage between +13.5 to +30 VDC. The power supply must be rated at 250mA minimum. The power supply should provide less than 1% ripple with 10% regulation.

Note:

The power supply should be dedicated to the LDT to prevent noise and external loads from affecting the EZ-track. When powering up more than one EZ-track on a single power supply, each EZ-track will draw no more than 250mA.

3.1: LT R10 Analog - LU (Voltage)

The LT R10 LU LDT generates a voltage output based on position. The LT R10 EZ-track with analog output offers 16 bits of resolution and is fully programmable over the entire active stroke length of the LDT. Keep in mind that there is a 2" Null zone at the connector end of the LDT and a 2.5" Dead zone at the other end of the LDT that the magnet must stay out of at all times. The units come fully programmed from the factory and do not require re-programming unless desired. The analog units are 100% absolute and will not lose programmed parameters on power loss. The analog output is referenced to the analog common terminal and should not be referenced to any of the other common terminals. To wire the LT R10 voltage LDT, see Section 3.4 and Figure 3-1. For programming Zero and Span, refer to Section 3.5.

3.2: LT R10 Analog - LI (Current)

The LT R10 LI LDT generates a current output based on position. The LT R10 EZ-track with analog output offers 16 bits of resolution and is fully programmable over the entire active stroke length of the LDT. Keep in mind that there is a 2" Null zone at the connector end of the LDT and a 2.5" Dead zone at the other end of the LDT that the magnet must stay out of at all times. The units come fully programmed from the factory and do not require re-programming on power loss. The analog output is referenced to the analog common terminal and should not be referenced to any of the other common terminals. To wire the LT R10 current LDT, see Section 3.4 and Figure 3-1. For programming Zero and Span, refer to Section 3.5.

Note:

LT R10 LI is current sourcing, which allows the current to flow from the LDT into the user's equipment.

3.3: LT R10 Analog - LD (Differential)

The LT R10 LD LDT's are available with an optional differential analog output. This feature is hardware specific and must be specified at time of order. The differential feature allows the distance between two magnets to be measured. The magnets must remain within the active stroke range at all times and cannot be any closer than 2.5" to each other. Keep in mind that there is a 2" Null area at the connector end of the LDT and a 2.5" Dead area at the other end of the LDT that the magnets must stay out of at all times. The units come fully programmed from the factory and do not require re-programming unless desired. The analog units are 100% absolute and will not lose programmed parameters on power loss. For programming ZERO and SPAN, refer to Section 3.6.

3.4: LT R10 - Analog Wiring

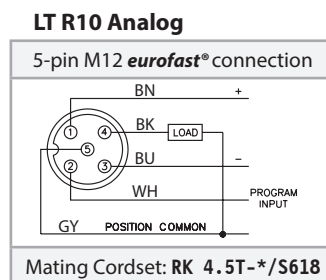

Figure 3-1: Analog Wiring Diagram

3.5: Setting Zero & Span Position - LI (Current) and LU (Voltage) Only

To set the ZERO and SPAN position for the LDT follow these steps:

1. Apply power to the LDT.
2. Place magnet assembly where ZERO is to be located, but within the active region of the probe.
3. Momentarily short the program input pin (pin 2) to the power supply common.
4. Place magnet assembly where SPAN is to be located, but within the active region of the probe.
5. Momentarily short the program input pin (pin 2) to the power supply + pin (the maximum distance must be within the active stroke range). This completes the programming process.

3.6: Setting Zero & Span Position - LD (Differential Analog) Only

The LT R10 analog LTD's are available with an optional differential analog output. This feature is hardware specific and must be specified at time of order. The differential feature allows the distance between two magnets to be measured. The magnets must remain within the active stroke range at all times and cannot be any closer than 2.5" to each other. Keep in mind that there is a 2" Null area at the connector end of the LDT and a 2.5" Dead area at the other end of the LDT that the magnet must stay out of at all times. The units come fully programmed from the factory and do not require re-programming unless desired. The analog units are 100% absolute and will not lose programmed parameters on power loss.

The differential feature is user programmable for ZERO and SPAN dimensions and can programmed anywhere within the active stroke range. The ZERO can either be programmed for fully open or closed.

To set the ZERO and SPAN position for the probe follow these steps:

1. Apply power to the probe.
2. Move the magnets to the desired minimum (ZERO) setting, but within the active region of the probe.
3. Momentarily short the program input pin to the power supply common.
4. Move the magnets to the desired maximum (SPAN) setting, but within the active region of the probe.
5. Momentarily short the program input pin to the power supply + pin (the maximum distance must be within the active stroke range).

This completes the programming process.

Note:

The maximum programmable stroke range on units with the differential analog output is 2.5" less than the active stroke. Refer to your part number label or Chapter 1 for active stroke range.

A.1: Troubleshooting for LT R10 Analog LDTs

Troubleshooting describes common problems that can occur when installing the LDT and offers possible solutions to these problems. If, after reading this appendix, a problem is still unresolved, please contact our technical support department. Troubleshooting is divided into the following two groups:

- General Checks
- Power Supply

General Checks

Make sure that the magnet is located within the LDT's active stroke area. Keep in mind that the LDT is programmable over the entire active stroke area. Refer to Section 3.4 for programming details. Captive magnet assemblies should be positioned so that they can move freely over the entire area of the active stroke without binding or pushing on the rod end. Non-captive magnet assemblies should be situated so that the magnet is no farther than 0.2" from the rod at any point in the magnet assembly's movement.

Note:

Ferromagnetic material (material readily magnetized) should be located no closer than 0.25" from the magnet or LDT rod end. This includes mounting brackets, magnet spacers, magnet brackets, and mounting screws. Ferromagnetic material can distort the magnetic field, causing adverse operation or failure of the LDT.

Check all LDT wires for continuity and/or shorts. It is preferable that the cable between the LDT and the interface device be one continuous run. If you are using a junction box, it is highly recommended that the splice junction box be free of AC and/or DC transient-producing lines. The shield should be carried through the splice and terminated at the interface device end.

Power Supply Check

This section will help you to determine if your power supply is adequate for the LDT to operate properly, or if the LDT's cable has a short or open.

In order for the EZ-track to operate properly, the external power supply must provide a level between 13.5 to 30 VDC. A power supply providing voltage above this specified range may damage the LDT. A power supply providing power below this specified range will not be sufficient to power the LDT. When powering more than one EZ-track on a single power supply, remember that each EZ-track requires three (3) watts of power. The amount of current draw will vary based on the input voltage used. To calculate the current draw for a particular LDT, divide the LDT wattage by the input voltage. For example, 3 watts divided by 24 VDC equals 125mA.

If the LDT is not operating properly, the LDT's cable may have an open or short, or the power supply is not supplying sufficient power. To verify this:

1. Turn the power supply off.
2. Remove the mating connector from the LDT.
3. Turn the power supply on.
4. Using a digital voltmeter, check across power supply common and customer supplied power (+VDC) on the mating end of the cable for a level between 13.5 and 30 VDC.

Note:

LDT's with potted cable assemblies should be checked for proper voltage at the power supply terminals. This cable assembly cannot be removed from the LDT.

If reading is between 13.5 and 30 VDC, turn power supply off and go to step 7. If the reading is below 13.5 VDC, either the power supply is not providing enough power or the LDT's cable possibly has a short/open. Reading of no voltage or minimal voltage (less than 5 volts) may be due to a short/ open in the cable. If reading is not between 13.5 and 30 VDC, go to step 5. If reading is above 30 VDC, adjust power supply or replace.

5. Turn the power supply off.
6. Check the continuity of the individual wires of the cable between the power supply and the LDT. Check for continuity from one end of the cable to the other. Also, verify that no shorts exist between pins.
7. Reconnect the mating connector to the LDT.

Appendix B: Ordering Information

B.1: Analog Part Numbering

A	B	C		D		E	F		G
LT	12	E	-	R10	-	LI	0	-	H1151

A	Type
LT	Linear Transducer

B	Measuring Span
*	Length of Measuring Span

C	Units of Measurement
E	Inches

D	Housing Size, Material
R10	10mm Rod, Aluminum
ER10	10mm Rod, Stainless Steel

E	Output Configuration
LI	Current
LU	Voltage
LD	Differential

F	Output Type		
	Current	Voltage	Differential
0	4-20mA	0 to 10V	0 to 10V
1	20-4mA	10 to 0V	4 - 20mA
4		0 to 5V	
5		5 to 0V	

G	Type of Connection
H1151	5-pin M12 eurofast® Connector

B.2: Accessories

Standard 4-Hole Magnet - Al	STM-AL-R10	Rod Support Bracket	RB-R10
Standard 4-Hole Magnet - SS	STM-SS-R10	Magnet Mount Bracket	MMB-R10
Standard Magnet Spacer	STS-R10	Egg Shape Float - SS	EF-R10
Split Magnet - Al	SPM-AL-R10	Miniature Float - SS	MF-R10
Split Magnet - SS	SPM-SS-R10	2 meter Cable, Straight Cordset	RK-4.5T-2/S618
Split Magnet Spacer	SPS-R10	4 meter Cable, Straight Cordset	RK-4.5T-4/S618
Cylinder Magnet	CM-R10	2 meter Cable, Right Angle Cordset	WK-4.5T-2/S618
Mounting Bracket Kit	MB-R10	4 meter Cable, Right Angle Cordset	WK-4.5T-4/S618

Appendix C: Specifications

General Specifications	
Rod End	316 Stainless Steel, 0.405" (10.29 mm) outer diameter
Mounting Hex	316 Stainless Steel, 1.75" (44.45 mm) across flats
Mounting Threads	3/4-16 UNF-2B x 1.00" (25.4 mm) with ESNA Jam Nut and O-ring seal
Head Assembly	Thick Wall Aluminum Cover with Viton O-ring Standard Gasket Seal at the Base and Connector Exit, NEMA 4
Connector	Standard, shielded 5-pin, M12 eurofast [®]
Displacement	Up to 168"
Electromagnetic Compatibility	IEC 801-2, Level 3 (Electrostatic discharge requirements) IEC 801-4, Level 3 (Electrical fast transient/burst requirements)
Dead Band	2.50" (63.5 mm) standard
Null Zone	2.00" (50.8 mm) standard
Head Enclosure	3" (76.20 mm) high with 1.75" (44.45 mm) diameter; hex and cover are NEMA 4

Electrical Specifications	
Input Voltage	Analog: 13.5 to 26.4 VDC
Current Draw	3 watts maximum, 200mA at 15 VDC (1 Watt, Typical)
Nonlinearity	Less than +/- 0.05% *
Repeatability	+/-0.001% of full stroke or 0.002" (0.0254 mm), whichever is greater.
Hysteresis	+/- 0.02% *
Temperature Coefficient LDT	Less than 0.00011 in./Degree F + [3 PPM/Degree F/in. of Full Stroke] (Less than 0.00503 mm/Degree C + [5.4 PPM/Degree C/mm of Full Stroke]).
Operating Temperature	
Head (Electronics)	-40° to +158° F (-40° to +70° C)
Guide Tube	-40° to +220° F (-40° to +105° C)
Storage Temperature	-40° to 185° F (-40° to +85° C)
Operating Pressure	5000 psi Operational, 10,000 psi Spike
Shock & Vibration	
Vibration	30 Grms.
Shock	2000 G.
* Specifications are based on a typical 36" stroke length.	

Analog Specifications	
Analog Output Drift	10ppm/Degree F (18ppm/Degree C)
Analog Output Loading	Voltage Output Minimum Load Resistance: 2Kohm Current Output Maximum Load Resistance: (Vin - 2)/0.02 Output Current: Guaranteed 6mA minimum for voltage units
Analog Ripple	<1 mV maximum (position output)
Update Time	1mS (stroke lengths 1" to 50") 3mS (stroke lengths 101" to 150") 2mS (stroke lengths 51" to 100") 4mS (stroke lengths 151" to 168")
Position Output	0 - 10 VDC, 16 Bits (65,535) resolution 4 - 20mA, 16 Bits (65,535) resolution
CE Approved with Connector Option "H1151" Only	
Output May Vary by 0.1% when Subjected to Severe Levels of Electrical Noise	

Notes:

TURCK



28 subsidiaries and over
60 representations worldwide!

Printed in USA

©2015 by Turck Inc. All rights reserved. No part of the
publication may be reproduced without written permission.